

CAD FILE:

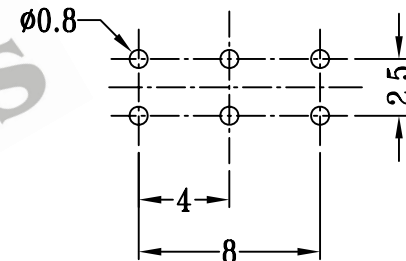
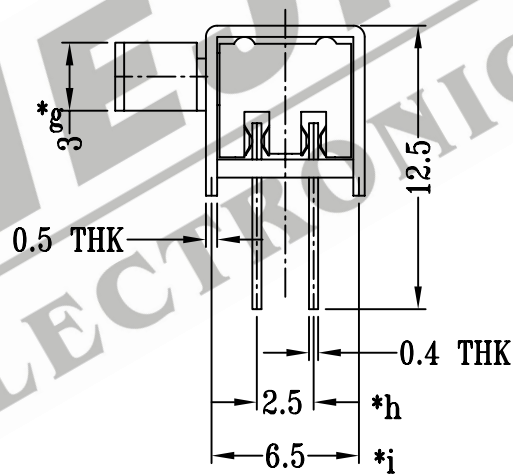
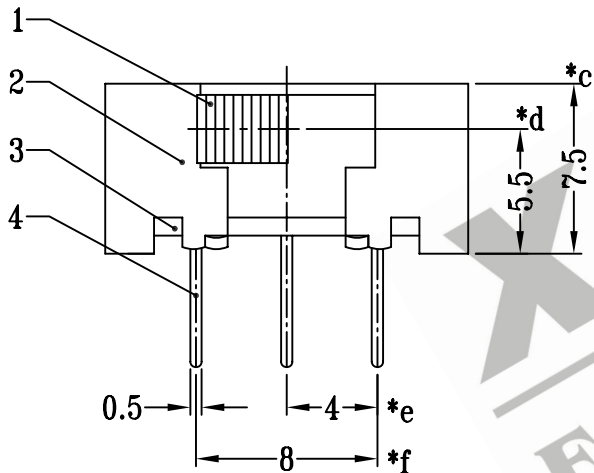
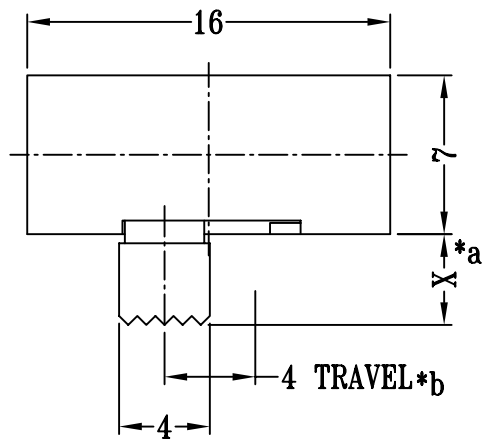

SCHEMATIC (NON-SHORTING)

P.C.B LAYOUT

注:带*表示关键尺寸(7个)

8					TOLERANCE UNLESS SPECIFIED	SHENZHEN XIEJIA ELECTRONICS CO.,LTD.				
7	CONTACT CLIP	PBS STRIP	2	Ag PLATED						
6	SPRING	STEEL WIRE	1	TEMPER	WITHIN:1.5±0.1mm	ISSUE	DATE	DESCRIPTIONS OF REVISION		APPD.
5	STEEL BALL	STEEL	1	NATURAL	OVER :1.5±0.2mm					
4	TERMINAL	BRASS STRIP	6	Ag PLATED OVER Ni PLATED	TITLE : HORIZONTAL SLIDE SWITCH		UNIT : mm	DRWG NO.: XJ-DR-SK22H05-00		
3	BASE	PHENOLIC RESIN	1	NATURAL	MODEL: SK-22H05		SCALE: 3:1	DWN.	ZHOUYU	2008-2-6
2	FRAME	STEEL STRIP	1	Ni PLATED	ALL MATERIALS MUST BE COMPLIANT TO ROHS			CHK'D	FANGYING	2008-2-6
1	KNOB	POM	1	BLACK			APPD.	KANGXINAN	2008-2-6	
NO.	PARTS	MATERIALS	Q'TY	FINISH						